

Multi-Pod (NZ) Limited

TEST REPORT

REPORT NUMBER
190910159GZU-001

ISSUE DATE
2019/11/12

PAGES
19

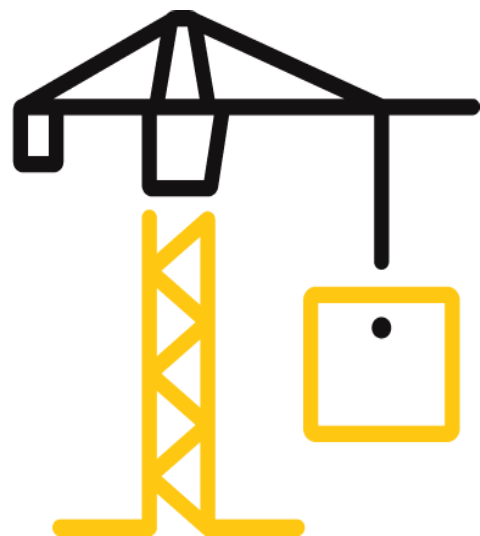

Test Report

Issue Date: 2019/11/12 Intertek Report No. 190910159GZU-001

Applicant: Multi-Pod (NZ) Limited

Applicant Address: 20 Oxford Street, Richmond, Nelson, 7020, New Zealand

Attn: Mr. Tony Frost

Manufacturer: ZhongShan BuildHome Building Materials Co., Ltd

Manufacturer Address: No.29 ShunJing Industrial Rd., BanFu Town ZhongShan GuangDong China 528459

Attn: Jacky Zhong

SUBJECT: Performance testing
<100mm Awning Window>

Dear Sir,

This test report for represents the results of our evaluation of the above referenced product(s) to the requirements contained in the following standards:

TEST METHODS AND STANDARDS
Refer to NZS 4211: 2008 - Specification for performance of windows (Amdt 1-2014)

SAMPLE ID	MODEL	SPECIFICATION
S190910159-001	BHDQ-3-AW-2	900 mm (Width) x2400 mm (Height) x 114.5 mm (Thickness)

SAMPLE RECEIVED: 2019/9/10
TESTED FROM: 2019/9/10 TO 2019/9/11

Test lab address: Room 4103 & 4203, No. 63, Punan Road, Huangpu District, Guangzhou, Guangdong Province, China

This report is for the exclusive use of Intertek's Client and is provided pursuant to the agreement between Intertek and its Client. Intertek's responsibility and liability are limited to the terms and conditions of the agreement. Intertek assumes no liability to any party, other than to the Client in accordance with the agreement, for any loss, expense or damage occasioned by the use of this report. Only the Client is authorized to permit copying or distribution of this report and then only in its entirety. Any use of the Intertek name or one of its marks for the sale or advertisement of the tested material, product or service must first be approved in writing by Intertek. The observations and test results in this report are relevant only to the sample tested. This report by itself does not imply that the material, product, or service is or has ever been under an Intertek certification program.

Test Report

Issue Date: 2019/11/12

Intertek Report No. 190910159GZU-001

Test Items, Method and Results:

1 Test Samples

A full scale sample of was provided by the manufacturer that was not weathered nor conditioned.

The description of the samples given below has been prepared from information provided by the sponsor of the test. All values quoted are nominal, unless tolerances are given.

Table 1 Product Information

1	Product Name	100mm Awning Window
2	Model	BHDQ-3-AW-2
3	Dimension of Windows Frame	900 mm (Width) x2400 mm (Height) x 114.5 mm (Thickness)
4	Dimension of Sash	Operable Sash: 730mm (Width) x 1386mm (Height) x 83.5mm (Thickness) Fixed Sash: 900(Width) x 900 mm (Height) x 100mm (Thickness)
5	Aluminum Profile	Model:SPEC100 Manufacturer: Guangdong xingfa
6	Frame Corner Construction Details: Joinery type	Mechanically assembled: Glued & screwed
7	Reinforcement	Not applicable
8	Glazing	Dimension: Operable Sash: 628(Width) x 1284 mm (Height), Fixed Sash: 765(Width) x 833mm (Height) Structure: 5mm+1.14PVB+5mm+12A+6mm tempered double glazing Supplier: Guangdong SunGlass
9	Hardware	Specify type: Awning window handle Model: CZS332 Supplier: KING LONG
10	Weather-strip	None
11	Thermal Break	Model : GRJ01 Supplier: Ke Yuan
12	Drainage	Sizes: 50mmx 8mm (Width x Height) quantity: 3 Sizes: 30mmx 8mm (Width x Height) quantity: 2

Test Report

Issue Date: 2019/11/12

Intertek Report No. 190910159GZU-001

13	Gasket (between leaf and frame)	Model: GA101, EP4855A Material: EPDM Supplier: WINGKAY
14	Sealant of Glass	Model: SS550 Material: silicone sealant Supplier: GuangDong BaiYun
15	Installation	The exterior perimeter of the test specimen was sealed with silicon sealant.

Test Report

Issue Date: 2019/11/12

Intertek Report No. 190910159GZU-001

Test Items, Method and Results:

2 Test Result

Table 2 Test Results

Test Description	Test Result		Rating	Verdict	
Serviceability Design Wind Pressure AS/NZS 4420.1-2016 section 3	± 3600 Pa		/	Pass	
Deflection / Span Ratio Framing member 1	Projected sash stile	1/1310			
Deflection / Span Ratio Framing member 2	Projected sash bottom rail	1/1320			
Deflection / Span Ratio Framing member 3	Transom	1/1360			
Operating Force AS/NZS 4420.1-2016 section 4	Initial Movement Requirement: <90N	Open	18 n	/	Pass
		Close	26 N		
	Maintain Movement Requirement: <90N	Open	10 N		
		Close	17 N		
Air Infiltration at ±150 Pa Overall area: 2.16 m ² AS/NZS 4420.1-2016 section 5	at +150Pa	1.96 L/s	Air conditioned	Pass	
	at -150Pa	2.15 L/s			
Water Penetration AS/NZS 4420.1-2016 section 6	No water penetration at:	455 Pa	Extra High	Pass	
	Description: No water penetration at 455 Pa.				
Ultimate Strength Test AS/NZS 4420.1-2016 section 7	± 5000 Pa with no collapse		/	Pass	
	Description: No significant breakage, permanent deformation or operational malfunction after ultimate strength was released.				

Test Report

Issue Date: 2019/11/12

Intertek Report No. 190910159GZU-001

Test Description	Test Result		Rating	Verdict
Torsional Strength NZS 4211-2008 section 11 and appendix A	Maximum deflection	4.40 mm	/	Pass

Test Report

Issue Date: 2019/11/12

Intertek Report No. 190910159GZU-001

Appendix A: Test Data and Sample Drawings:

A.1 Deflection Test – Test method AS/NZS 4420.1-2016

Test Pressure (Serviceability design wind pressure), P=3600 Pa.

Unless a smaller value of allowable deflection is separately specified for windows that are subject to specific design, in buildings requiring specific design, the maximum deflection due to bending of any structural member, including the outer window frame, measured relative to the end of the member at the serviceability limit state shall not exceed span/200 of the span.

Table 3 Test Data of Deflection Test

Member (mm)		Test Pressure (Pa)	Deflection(mm)			Actual Deflection	Deflection/Span Ratio
Item	Span Length		1	2	3		
Projected sash stile	1310	+P/4=900	0.9	1.1	0.8	0.3	/
		+2P/4=1800	1.8	2.3	1.9	0.5	/
		+3P/4=2700	2.8	3.6	3.0	0.7	/
		+4P/4=3600	3.6	4.7	3.9	1.0	1:1310
		0	0.4	0.2	0.1	0.2	/
Projected sash stile	1310	-P/4=-900	1.0	1.2	1.0	0.2	/
		-2P/4=-1800	1.7	2.2	1.9	0.4	/
		-3P/4=-2700	2.7	3.8	3.3	0.8	/
		-4P/4=-3600	3.5	4.8	4.3	0.9	1:1456
		0	0.3	0.2	0.2	0.1	/

Table 4 Test Data of Deflection Test

Member (mm)		Test Pressure (Pa)	Deflection(mm)			Actual Deflection	Deflection/Span Ratio
Item	Span Length		3	4	5		
Projected sash bottom rail	660	+P/4=900	0.8	1.1	1.2	0.2	/
		+2P/4=1800	1.9	2.4	2.4	0.3	/
		+3P/4=2700	3.0	3.5	3.3	0.4	/
		+4P/4=3600	3.9	4.5	4.2	0.5	1:1320
		0	0.1	0.1	0.1	<0.1	/
Projected sash bottom rail	660	-P/4=-900	1.0	1.1	1.0	0.1	/
		-2P/4=-1800	1.9	2.1	1.8	0.3	/
		-3P/4=-2700	3.3	3.6	3.1	0.4	/
		-4P/4=-3600	4.3	4.6	4.0	0.5	1:1320
		0	0.2	0.2	0.2	<0.1	/

Test Report

Issue Date: 2019/11/12

Intertek Report No. 190910159GZU-001

Table 5 Test Data of Deflection Test

Member (mm)		Test Pressure (Pa)	Deflection(mm)			Actual Deflection	Deflection/Span Ratio
Item	Span Length		6	7	8		
Transom	680	+P/4=900	0.6	0.9	1.0	0.2	/
		+2P/4=1800	1.3	1.7	1.8	0.3	/
		+3P/4=2700	2.0	1.5	2.4	0.3	/
		+4P/4=3600	2.6	3.2	2.9	0.5	1:1360
		0	0.1	0.1	0.1	<0.1	/
Transom	680	-P/4=-900	0.9	1.0	0.8	0.2	/
		-2P/4=-1800	1.8	1.8	1.5	0.2	/
		-3P/4=-2700	3.0	3.1	2.6	0.3	/
		-4P/4=-3600	3.9	4.0	3.3	0.3	1:2267
		0	0.2	0.1	0.1	0.1	/

Test Report

Issue Date: 2019/11/12

Intertek Report No. 190910159GZU-001

A.2 Air infiltration test – Test method AS/NZS 4420.1-2016

Overall area: 2.16 m² Joint Length: 4.23 m

Table 6 Test Data of Air Infiltration Test

Test pressure of 150 Pa	Infiltration rate (positive direction)	1.96 L/s
	Exfiltration rate (negative direction)	2.15 L/s
	Average air leakage rate	2.05 L/s
	Rating	Air conditioned
	Requirement: Geometric mean	2.96 L/s

A.3 Torsional Test – Test method NZS 4211-2008

Table 7 Test Data of Torsional Strength of Sashes

Torsional Test					
Load	10N	20N	30N	40N	45N
Maximum deflection	1.10mm	1.67mm	2.60mm	3.67mm	4.40mm

The maximum deflection of a glazed projecting sash shall not exceed 0.04 times the length of the shortest of two members joined at the point of load, or 50 mm whichever is the lesser: the required deflection is 27.8mm(=0.04x695mm).

Test Report

Issue Date: 2019/11/12

Intertek Report No. 190910159GZU-001

A.4 Sample Drawings

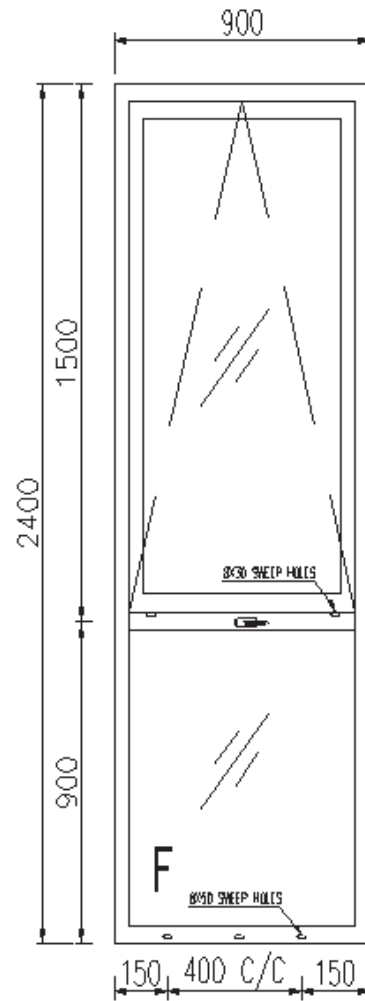

Fig.1 Drawing of Representative Sample

Test Report

Issue Date: 2019/11/12

Intertek Report No. 190910159GZU-001

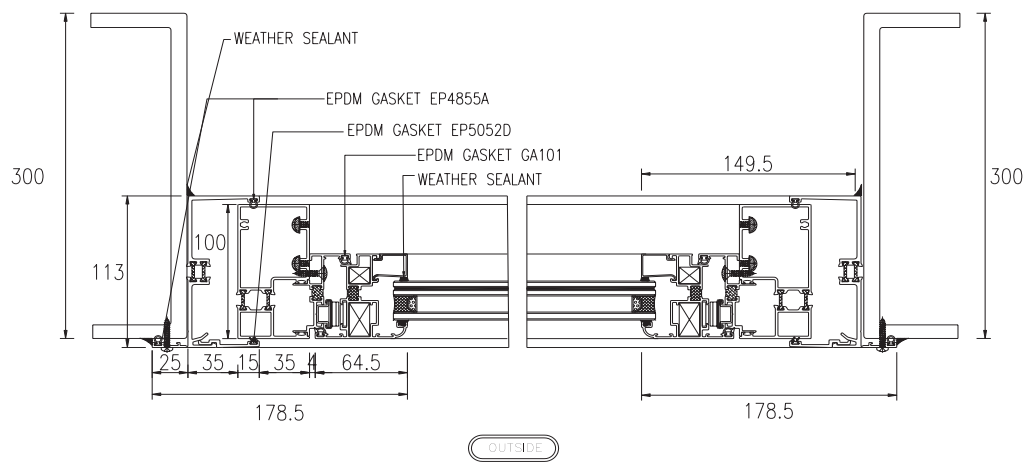

Fig.2 Drawing of Representative Sample

Test Report

Issue Date: 2019/11/12

Intertek Report No. 190910159GZU-001

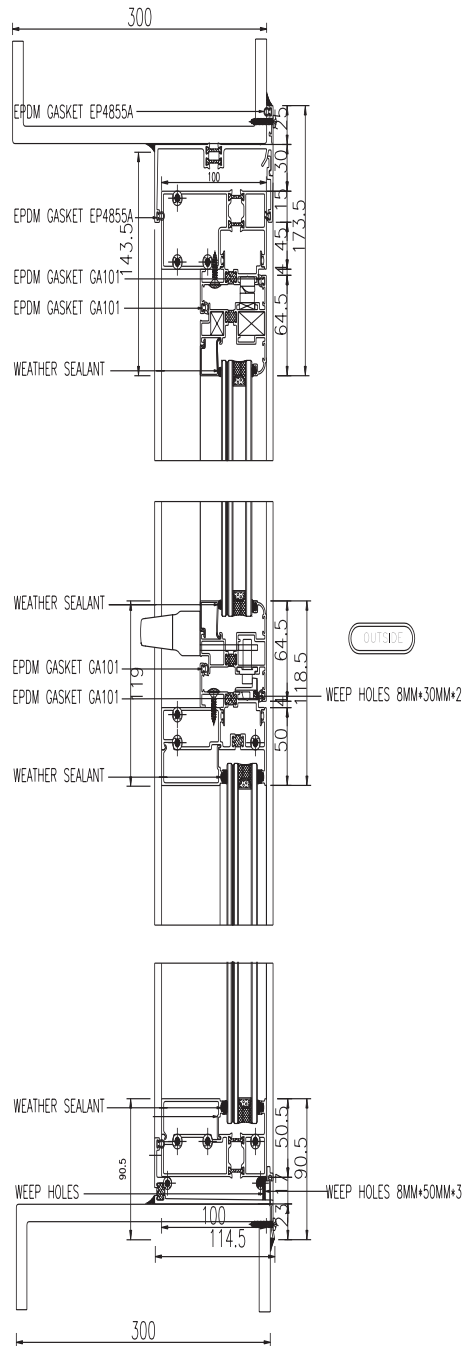

Fig.3 Drawing of Representative Sample

Test Report

Issue Date: 2019/11/12

Intertek Report No. 190910159GZU-001

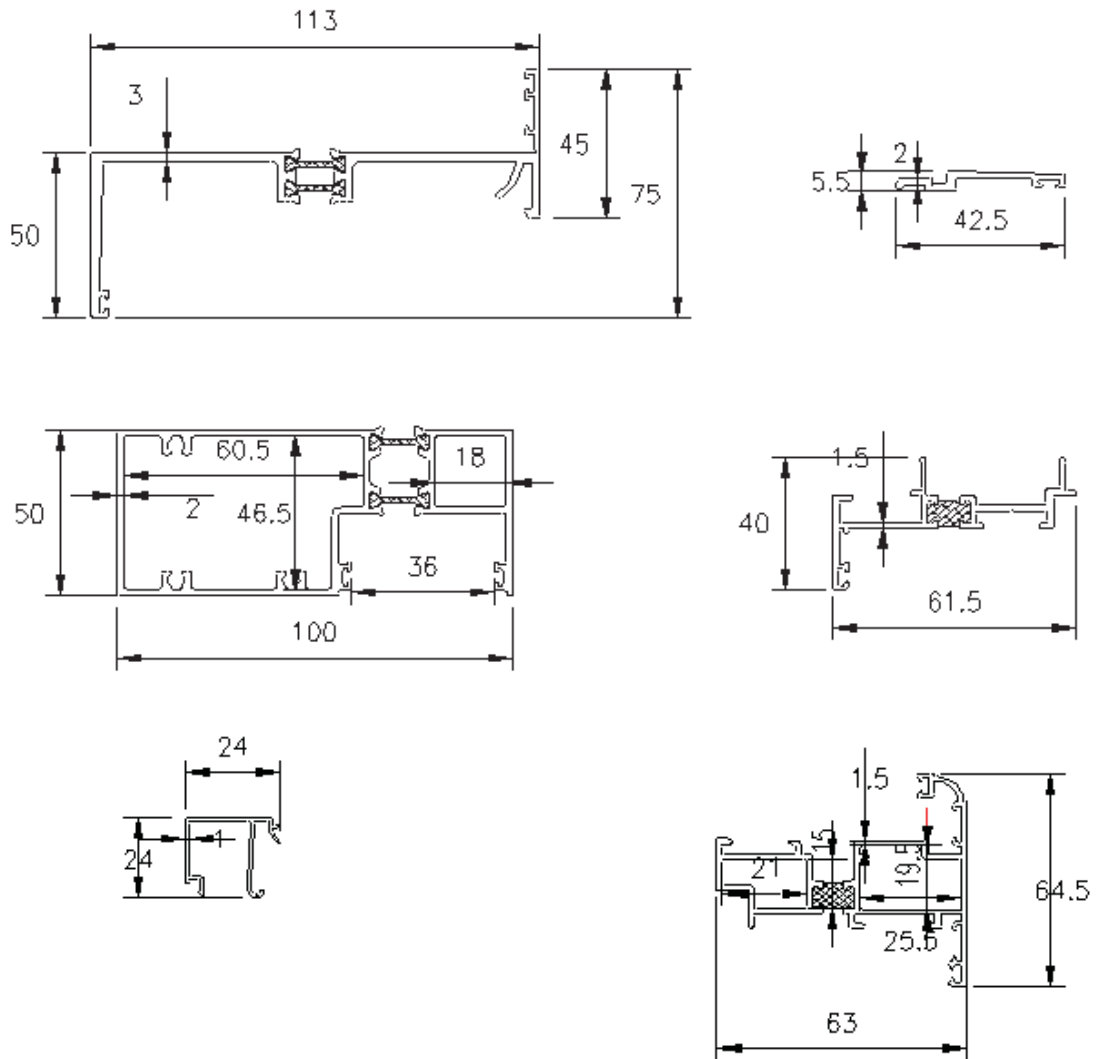

Fig.4 Drawing of Representative Sample

Test Report

Issue Date: 2019/11/12

Intertek Report No. 190910159GZU-001

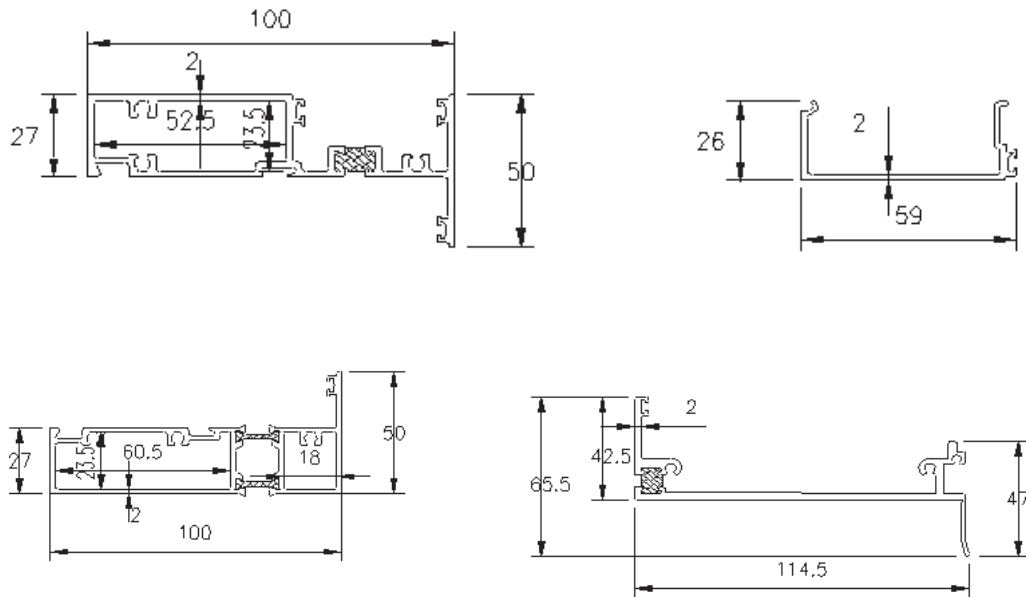

Fig.5 Drawing of Representative Sample

Test Report

Issue Date: 2019/11/12

Intertek Report No. 190910159GZU-001

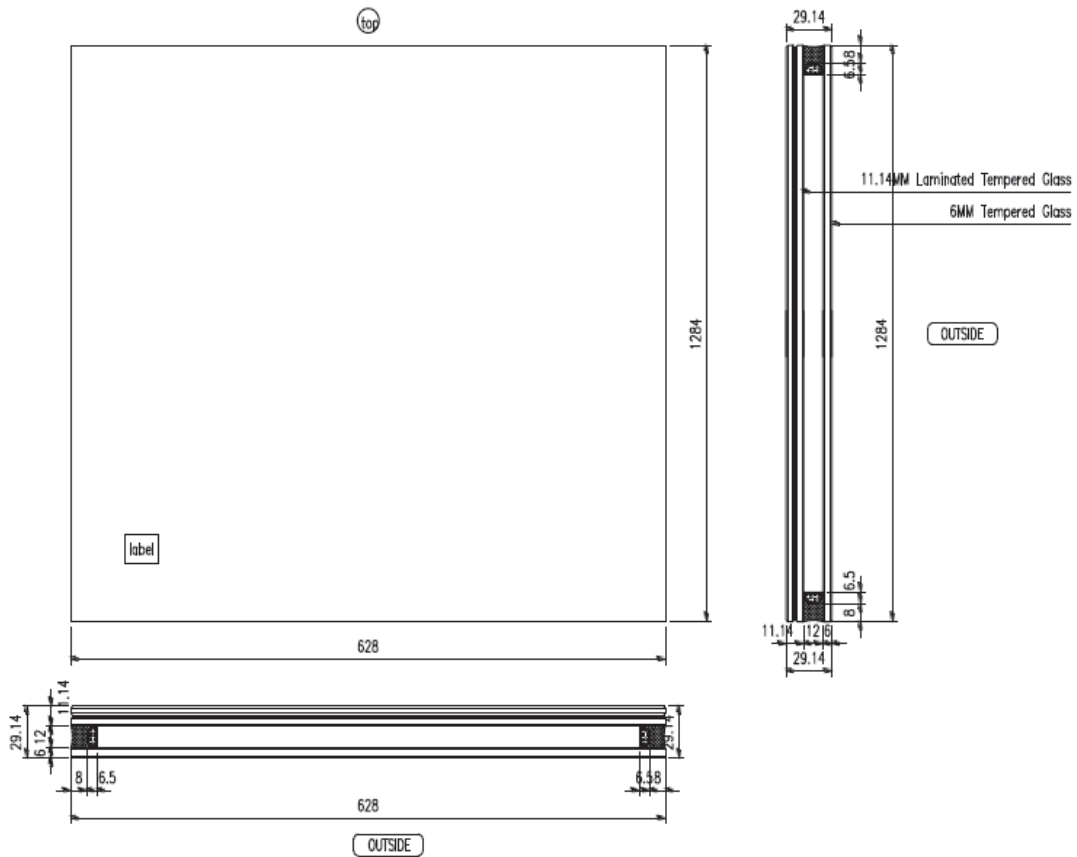

Fig.6 Drawing of Glazing Structure

Test Report

Issue Date: 2019/11/12

Intertek Report No. 190910159GZU-001

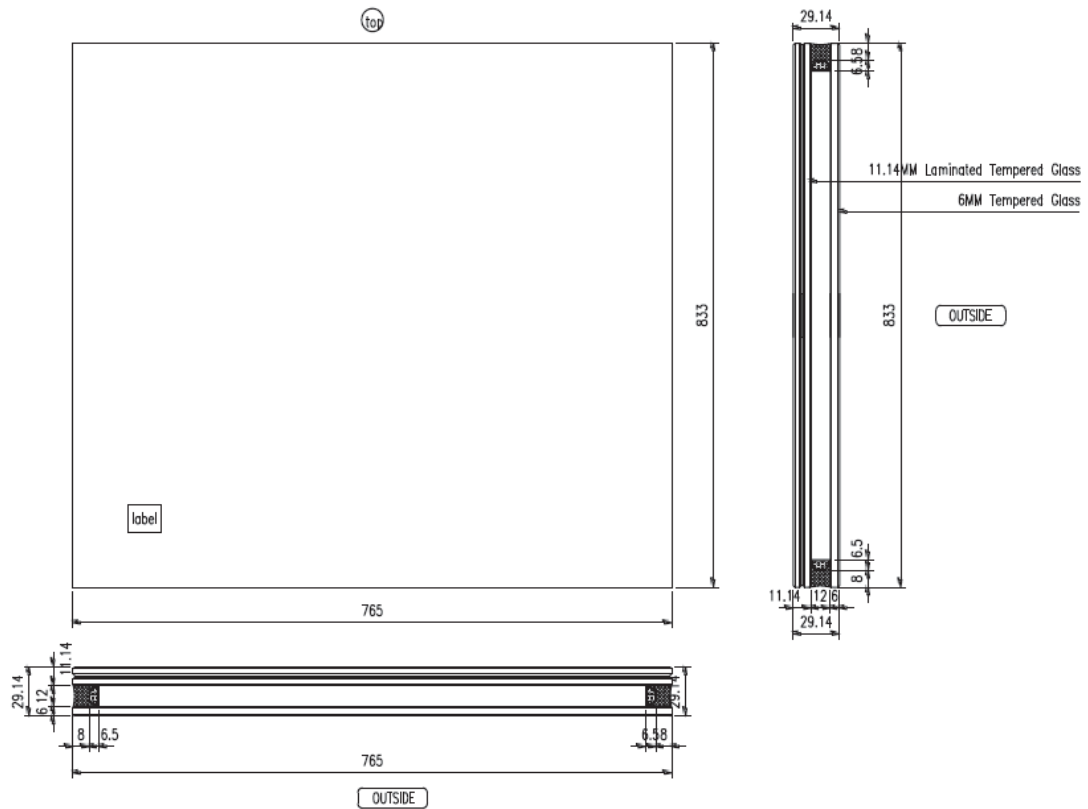

Fig.7 Drawing of Glazing Structure

Test Report

Issue Date: 2019/11/12

Intertek Report No. 190910159GZU-001

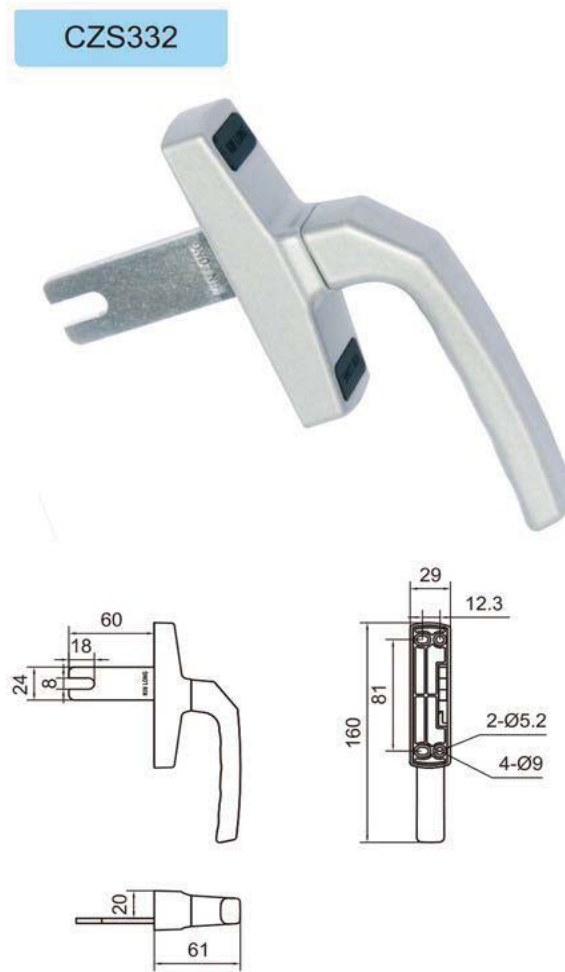

Fig.8 Drawing of Representative Sample

Test Report

Issue Date: 2019/11/12

Intertek Report No. 190910159GZU-001

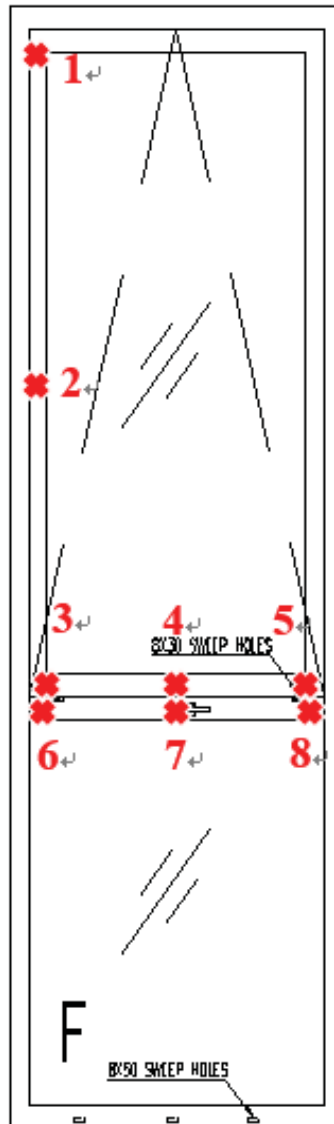

Fig.9 Locations of Displacement Measuring Devices

Test Report

Issue Date: 2019/11/12

Intertek Report No. 190910159GZU-001

APPENDIX : SAMPLE RECEIVED PHOTO

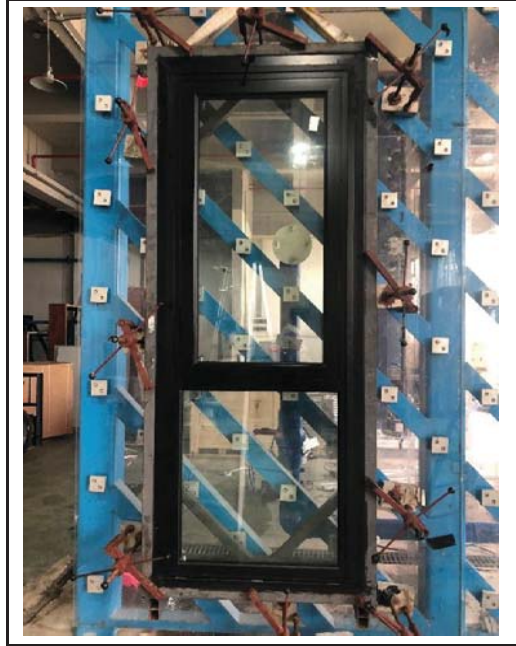

REPORT AUTHORIZED

When signed with physical or electronic signature, the contents of this report have been prepared and approved per Intertek's quality process in accordance with ISO 17025.

Approved by:

Prepared by:

Oliver Zhu

Ziqing Chen

Name: Oliver Zhu

Name: Ziqing Chen

Title: Reviewer

Title: Project Engineer

Revision:

Report NO.	DATE	Revision Reason	Revision Summary	AUTHOR	REVIEWER
190910159GZU-001	2019/11/12	0	First issue	Ziqing Chen	Oliver Zhu

End of Test Report